



End cap VER01

DESCRIPTION

- Rubberized outer jacket
- Sealing material: NBR, FKM
- Material stiffening plate: Unalloyed steel DIN EN 10139 (DIN 1624)

FUNCTION

- Static sealing of bores in housings, e.g. shaft bushings in gearbox housings
- Sealing effect due to interference fit
- Partially rubberized outer diameter ensures tight fit and seal between outer jacket and housing bore
- Self-retaining

PRODUCT ADVANTAGES

- Good static sealing effect with low-viscosity or gaseous media
- Good static sealing effect due to smooth outer jacket
- Compensates for thermal expansion, e.g. in light metal housings, good sealing effect with greater roughness and with split housings
- Reliable design with broad application spectrum for moderately demanding applications in general industry
- Good price/performance ratio

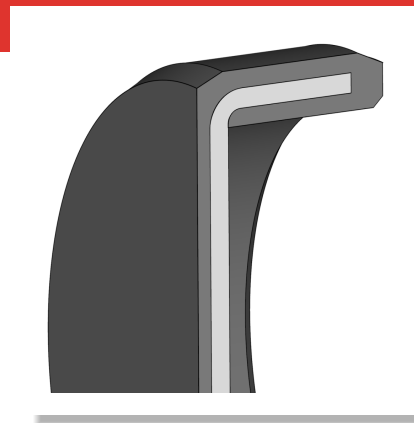
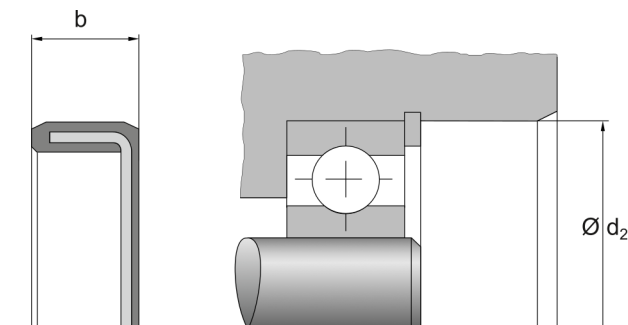

- Manufactured by certified external suppliers

APPLICATIONS

- Gearboxes
- Bearing pedestal seal

APPLICATION LIMITS

- At higher pressures, the end cap should be secured, e.g. with a retainer ring
- Pressure [Mpa]: max. 0,05
- The values given here are maximum values and may not all be reached at the same time.

NBR

- Temperature [°C]: -40 to 80, short-term up to 100

FKM

- Temperature [°C]: -25 to 150

MEDIA RESISTANCE

NBR

- Good chemical resistance to various mineral oils and greases (H, HL, HLP)
- Flame-retardant hydraulic fluids HFA and HFB, HFC up to appr. +50°C
- Water up to max. +60°C
- Low resistance to ozone, weathering and ageing

FKM

- Good chemical resistance to mineral oils and greases, synthetic oils and greases, engine, gearbox and ATF oils up to approx. +150 °C
- Fuels, flame-retardant pressure fluids HFD, aliphatic, aromatic and chlorinated hydrocarbons
- Water up to max. +60°C
- Very good resistance to ozone, weathering and ageing



DICHTOMATIK

End cap VER01

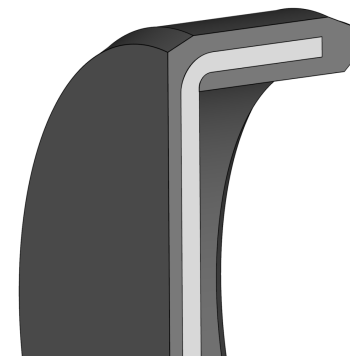

CONFORMITY AND CERTIFICATES

- Please consult the material data sheet valid for the respective material for current information on approvals and certificates, as this information depends on the compound and cannot be listed exhaustively here.

DESIGN GUIDELINE

- Design of the installation space is recommended in accordance with DIN 3760.

INSTALLATION GUIDELINE

- Do not grease the seal or installation space for assembly
- Hold the press-in device in the end position for some time so that spring-back or skewing is reduced to a minimum

STORAGE ADVISE

- Storage temperature <math><25^{\circ}\text{C}</math>
- No direct heat sources
- No direct sunlight
- No condensation in the storage room
- No exposure to ozone or ionizing radiation
- Recommendations based on the revision of ISO 2230 dated 16.09.1992

The information contained herein is believed to be reliable, but no representations, warranties or guarantees of any kind are made as to its accuracy or suitability for any purpose. The information reproduced herein is based on laboratory testing and is not necessarily indicative of end product performance. Complete testing and performance of the end product is the responsibility of the user.

© Freudenberg FST GmbH | dichtomatik.fst.com

