

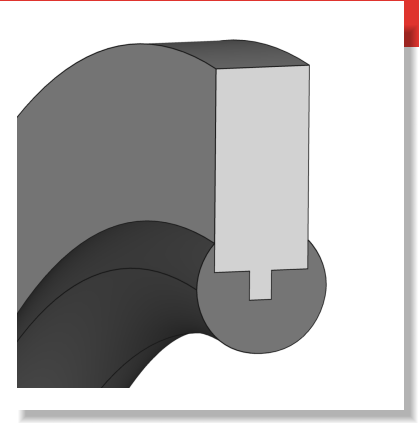

Bonded seal USZO



DESCRIPTION

- Elastomer sealing lip vulcanized on the inside
- Round lip design
- Sealing material: NBR, FKM
- Material metal ring: Standard steel SAE 1008 (1.0330), zinc chromated (CR VI free) / stainless and acid-resistant steel AISI 304 (1.4301)

FUNCTION

- Protection against dirt from outside, prevents media leakage, no pressure loss
- Sealing effect due to compression of the elastomer lip

PRODUCT ADVANTAGES

- Optimized sealing effect due to elimination of cavities
- Very good sealing effect
- Metal washer ensures controlled pressing
- Easy assembly and disassembly
- Reliable design with broad application spectrum for moderately demanding applications in general industry
- Good price/performance ratio
- Manufactured by certified external suppliers

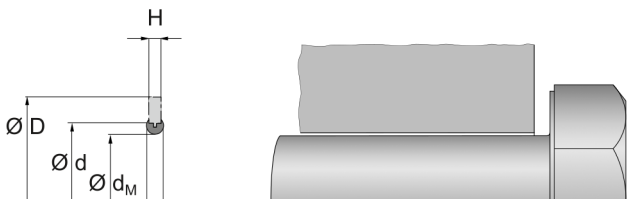

APPLICATIONS

- Static sealing for screw connections and flange seals (mechanical engineering, tank and apparatus construction)

APPLICATION LIMITS

- Fastener seals are suitable for pressures up to max. 25 MPa without countersinking in the mating surfaces. Higher pressures possible with countersink, depending on application parameters
- The values given here are maximum values and may not all be reached at the same time.

NBR

- Temperature [°C]: -30 to 100

FKM

- Temperature [°C]: -20 to 200

MEDIA RESISTANCE

NBR

- Good chemical resistance to various mineral oils and greases (H, HL, HLP)
- Flame-retardant hydraulic fluids HFA and HFB, HFC up to appr. +50°C
- Water up to max. +60°C
- Low resistance to ozone, weathering and ageing

FKM

- Good chemical resistance to mineral oils and greases, synthetic oils and greases, engine, gearbox and ATF oils up to approx. +150 °C
- Fuels, flame-retardant pressure fluids HFD, aliphatic, aromatic and chlorinated hydrocarbons
- Water up to max. +60°C
- Very good resistance to ozone, weathering and ageing



Bonded seal USZO

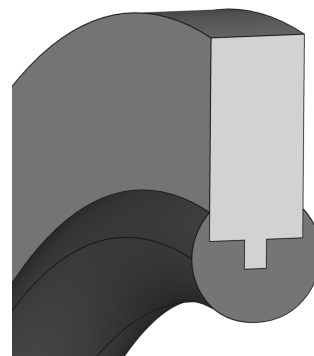

CONFORMITY AND CERTIFICATES

- Please consult the material data sheet valid for the respective material for current information on approvals and certificates, as this information depends on the compound and cannot be listed exhaustively here.

DESIGN GUIDELINE

- Flat surface
- Surface roughness $R_{max} \leq 15 \mu m$
- Surface roughness $R_a = 3 \mu m$

INSTALLATION GUIDELINE

- Clean the installation space carefully before installation, remove dust, dirt, metal chips, etc.
- Avoid any damage during installation

STORAGE ADVISE

- Storage temperature $< 25^\circ C$
- No direct heat sources
- No direct sunlight
- No condensation in the storage room
- No exposure to ozone or ionizing radiation
- Recommendations based on the revision of ISO 2230 dated 16.09.1992

The information contained herein is believed to be reliable, but no representations, warranties or guarantees of any kind are made as to its accuracy or suitability for any purpose. The information reproduced herein is based on laboratory testing and is not necessarily indicative of end product performance. Complete testing and performance of the end product is the responsibility of the user.

© Freudenberg FST GmbH | dichtomatik.fst.com

