

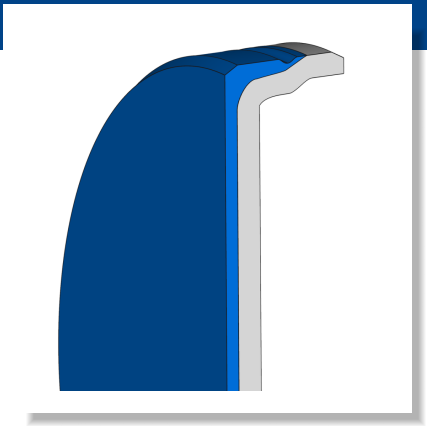

## End cap GSA



### DESCRIPTION

- Vulcanized metal angle ring
- Half-shoulder outer jacket (rubber-metal)
- Sealing Material: NBR
- Material enforcement sheet: unalloyed steel DIN EN 10139 (DIN 1624)

### FUNCTION

- Static sealing of bores in housings, e.g. shaft bushings in gearbox housings
- Sealing effect due to interference fit
- Partially rubberized outer diameter ensures tight fit and seal between outer jacket and housing bore
- Self-retaining

### PRODUCT ADVANTAGES

- Good static sealing effect with low-viscosity or gaseous media
- Good static sealing effect due to smooth outer jacket
- Robust design
- Market-leading, proprietary design with the widest range of applications in all industries and for a variety of requirements
- Highest quality, durability and safety

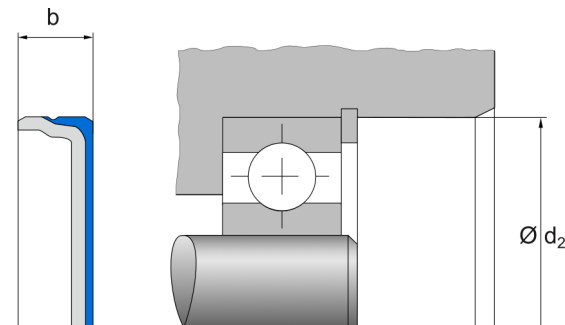

- Best results in total cost of ownership

### APPLICATIONS

- Drilling and assembly feedthroughs in housings
- General mechanical engineering

### APPLICATION LIMITS

- Permissible maximum values depending on the other operating conditions, see technical manual.

### MEDIA RESISTANCE

- Please refer to resistance information in the chemical resistance guide at [www.fst.com](http://www.fst.com).

### CONFORMITY AND CERTIFICATES

- Please consult the material data sheet valid for the respective material for current information on approvals and certificates, as this information depends on the compound and cannot be listed exhaustively here.

### DESIGN GUIDELINE

- Please refer to the technical manual for design guidelines.

### INSTALLATION GUIDELINE

- The prerequisite for perfect function of the seal is careful installation in accordance with the technical manual.

### STORAGE ADVISE

- Storage temperature <25°C
- No direct heat sources
- No direct sunlight
- No condensation in the storage room
- No exposure to ozone or ionizing radiation



## End cap GSA

- Recommendations based on the revision of ISO 2230 dated 16.09.1992

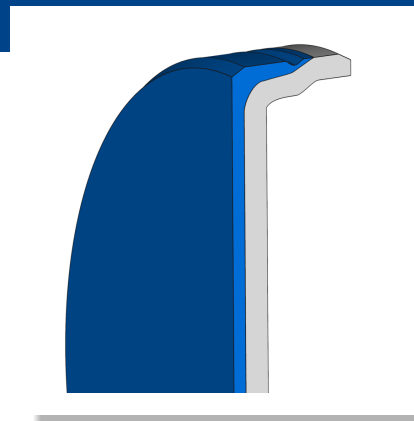

The information contained herein is believed to be reliable, but no representations, warranties or guarantees of any kind are made as to its accuracy or suitability for any purpose. The information reproduced herein is based on laboratory testing and is not necessarily indicative of end product performance. Complete testing and performance of the end product is the responsibility of the user.  
© Freudenberg FST GmbH | [www.fst.com](http://www.fst.com)