

## Piston guide ring FRK 05

### DESCRIPTION

- Chamfered on both sides
- Textured surface
- Slotted
- Material: Hard fabric

### FUNCTION

- Dissipation of transverse forces
- Guiding of pistons
- Reduces the danger of metallic contact
- Ensures concentricity within the cylinder
- Lubricant depot due to surface structure

### PRODUCT ADVANTAGES

- Minimized stick-slip effect
- Simple snap-on assembly
- Use at high surface pressures
- Extended cylinder life
- Reliable design with broad application spectrum for moderately demanding applications in general industry
- Good price/performance ratio
- Manufactured by certified external suppliers

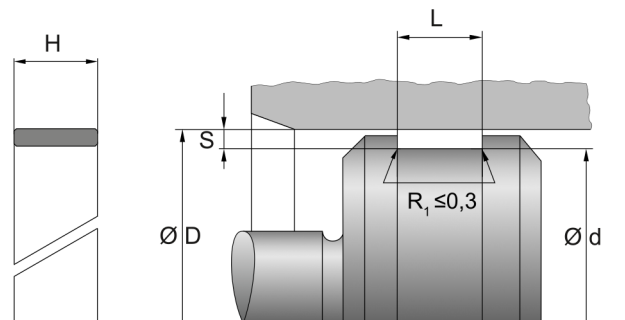

### APPLICATIONS

- Mobile hydraulics
- Heavy hydraulics

### APPLICATION LIMITS

- Temperature [°C]: -50 to 120
- Gliding speed [m/s]: max. 1
- Dynamic contact pressure [N/mm²]: max. 100
- The values given here are maximum values and may not all be reached at the same time.

### MEDIA RESISTANCE

- Hydraulic oils according to DIN 51524 part 1-3
- Lubricating oils
- Lubricating greases based on minor oils
- Flame-retardant hydraulic fluids HFA, HFB, HFC according to VCMA 24317

### CONFORMITY AND CERTIFICATES

- Please consult the material data sheet valid for the respective material for current information on approvals and certificates, as this information depends on the compound and cannot be listed exhaustively here.

### DESIGN GUIDELINE

- Cylinder housing and piston rod/piston must be chamfered to prevent damage
- Length and angle of the installation chamfers must be in accordance with installation space drawing
- Surface roughness of mating surface according to specifications of seal used
- Surface roughness of groove flanks  $R_a \leq 3 \mu\text{m}$
- Surface roughness of groove base  $R_a \leq 2,5 \mu\text{m}$



 DICHTOMATIK

## Piston guide ring FRK 05

### INSTALLATION GUIDELINE

- Installation in a closed, cut groove
- Assembly is supported by chamfers on both sides
- Simple installation of the slotted guide rings

### STORAGE ADVISE

- Storage temperature <25°C
- No direct heat sources
- No direct sunlight
- No condensation in the storage room
- No exposure to ozone or ionizing radiation
- Recommendations based on the revision of ISO 2230 dated 16.09.1992

The information contained herein is believed to be reliable, but no representations, warranties or guarantees of any kind are made as to its accuracy or suitability for any purpose. The information reproduced herein is based on laboratory testing and is not necessarily indicative of end product performance. Complete testing and performance of the end product is the responsibility of the user.

© Freudenberg FST GmbH | [dichtomatik.fst.com](http://dichtomatik.fst.com)