

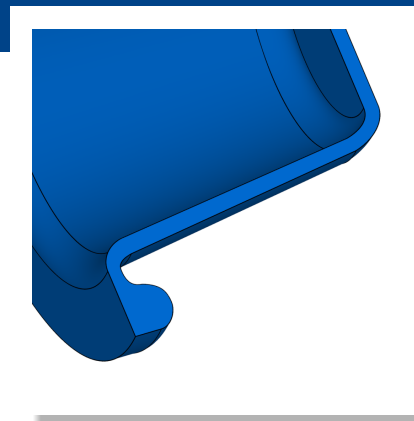

Fabric-reinforced diaphragm BFA



DESCRIPTION

- Thin-walled, sensitive special diaphragms made of rubber-elastic materials with fabric reinforcement
- Sealing material: NBR

FUNCTION

- Flexible separation of two media
- Regulation, measuring and control function, force conversion

PRODUCT ADVANTAGES

- No additional adjustment resistance during start-up or when changing the direction of movement
- Highest quality
- Low, almost constant adjustment resistance over the entire stroke
- Constant effective area over the entire stroke
- No rest point in the working area
- Significantly longer stroke lengths compared to conventional diaphragms of the same diameter
- Long service life

APPLICATIONS

- Hydraulically and pneumatically actuated control and regulating devices
- Pressure switches

- Pressure intensifiers and measuring and display devices
- Wireless version: use at low pressures

APPLICATION LIMITS

- Permissible maximum values depending on the other operating conditions, see technical manual.

MEDIA RESISTANCE

- Please refer to additional information in the chemical resistance guide at www.fst.com.

CONFORMITY AND CERTIFICATES

- Please consult the material data sheet valid for the respective material for current information on approvals and certificates, as this information depends on the compound and cannot be listed exhaustively here.

DESIGN GUIDELINE

- Please refer to the technical manual for design guidelines.

INSTALLATION GUIDELINE

- The prerequisite for perfect function of the seal is careful installation in accordance with the technical manual.

STORAGE ADVISE

- Storage temperature <25°C
- No direct heat sources
- No direct sunlight
- No condensation in the storage room
- No exposure to ozone or ionizing radiation
- Recommendations based on the revision of ISO 2230 dated 16.09.1992

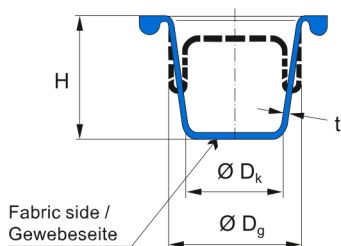

Fabric-reinforced diaphragm BFA

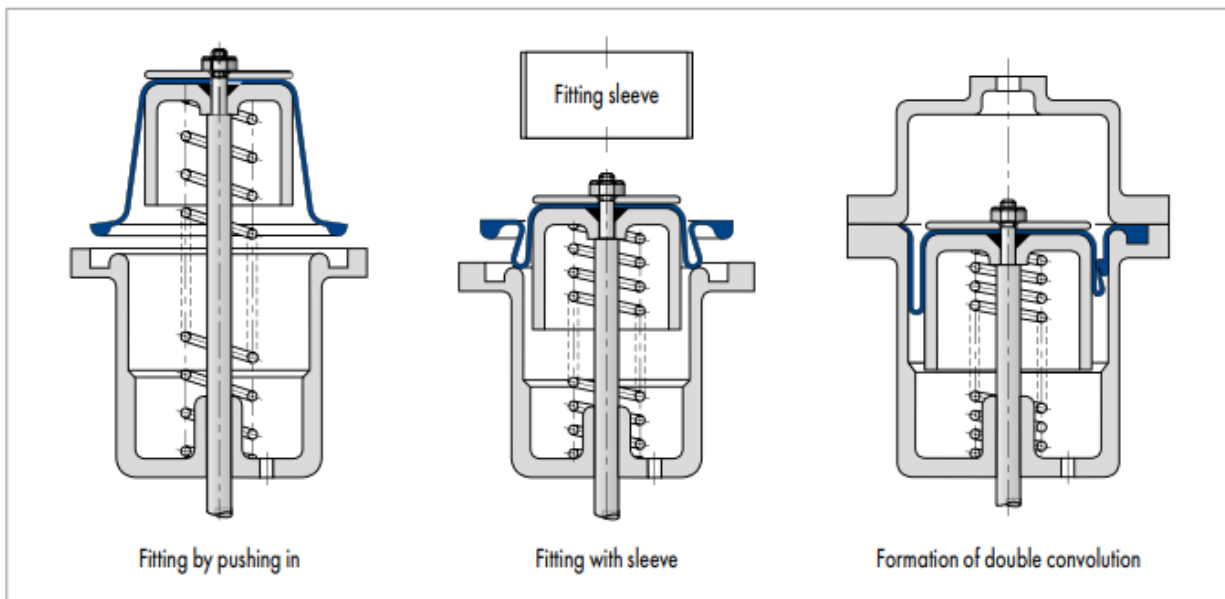
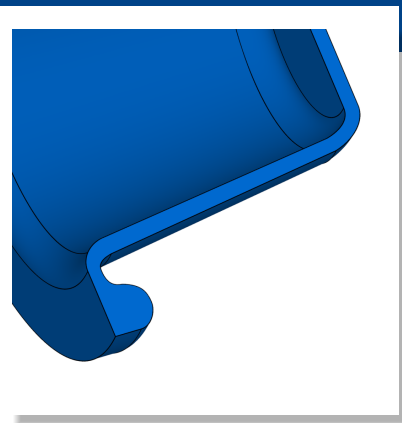

Fitting

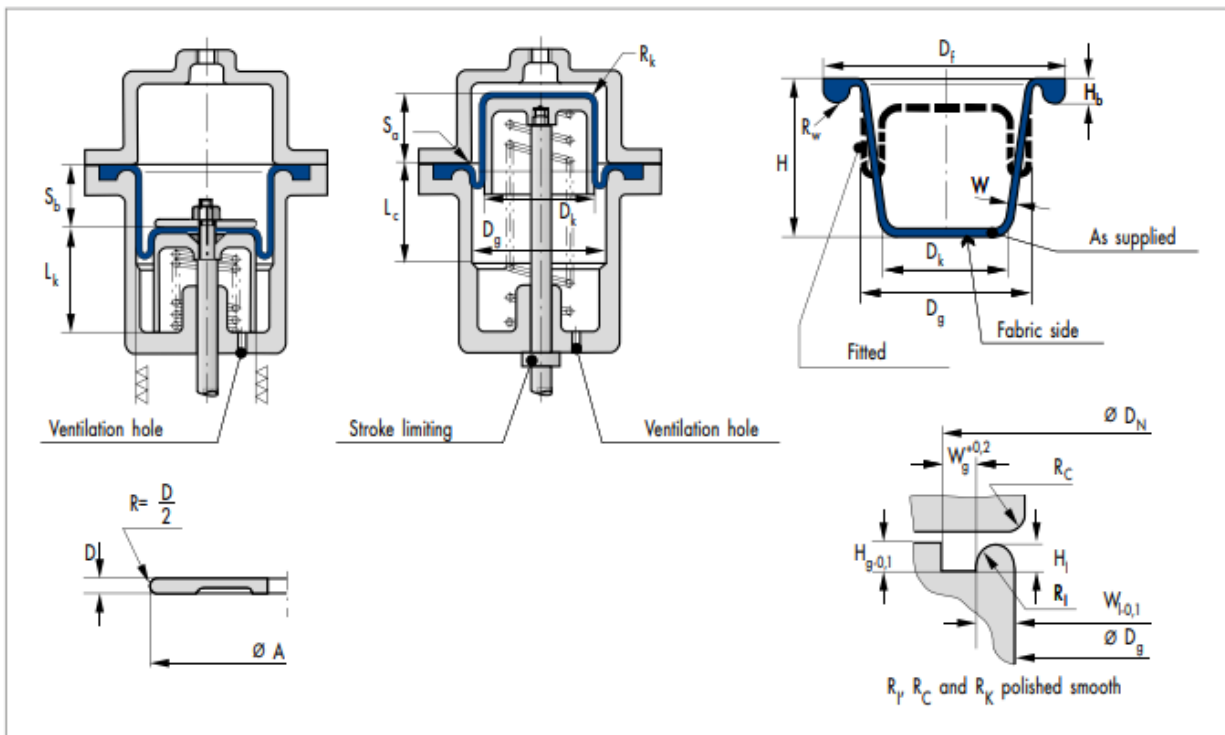



Fabric-reinforced diaphragm BFA



Cylinder Ø	D _g	up to 60 mm	up to 100 mm	up to 150 mm	>150 mm
Installation dimensions					
Piston Ø	D _k	D _g -5	D _g -10	D _g -10	D _g -10
Groove Ø	D _n	D _g +15	D _g +21	D _g +27,5	D _g +27,5
Piston radius	R _k	3,50	4,50	5,80	7,00
Cover radius	R _c	2,00	2,00	2,00	2,00
Groove depth	H _g	3,00	4,00	5,00	5,00
Groove width	W _g	4,00	5,50	7,20	7,20
Rim width	W _i	3,50	5,00	6,50	6,50
Rim height	H _i	2,30	3,10	3,50	3,50
Rim radius	R _i	1,75	2,50	3,25	3,25
Diaphragm dimensions					
Flange Ø	D _f	D _g +14	D _g +20	D _g +26	D _g +26
Wall thickness	W	0,45	0,55	0,80	1,00
Flange bead	H _b	3,60	5,00	6,30	6,30
Radius	R _w	1,75	2,50	3,25	3,25
Minimum length of finely machined areas					
on the piston	L _k	0,5 (H+S _a)	0,5 (H+S _a)	0,5 (H+S _a)	0,5 (H+S _a)
on the cylinder	L _c	0,5 (H+S _b)	0,5 (H+S _b)	0,5 (H+S _b)	0,5 (H+S _b)
Diaphragm stroke					
in one direction max.	S _a	H-8	H-14	H-20	H-20
in opposite direction max.	S _b	H-8	H-14	H-20	H-20
Fastening plate					
	a	D _k +2,9	D _k +4,1	D _k +5,6	D _k +6
	D	1,5	3,0	4,0	5,0